

CREATION AUDIO LABS, INC.

MW1

STUDIO TOOL

---

# OPERATOR'S MANUAL

Revised 2011-05-02

---

## TABLE OF CONTENTS

INTRODUCTION_____	2
WARRANTY_____	3
SERVICE_____	4
SAFETY_____	5
SPECIFICATIONS_____	6
OVERVIEW_____	7
QUICK REFERENCE DIAGRAM_____	8
APPLICATIONS QUICK REFERENCE DIAGRAMS_____	9-16
QUICK REFERENCE_____	17-19
DETAILED OPERATION_____	20-28
DECLARATION of CONFORMITY_____	29

CREATION AUDIO LABS, INC.

MW1

STUDIO TOOL

---

## INTRODUCTION

Thank You for your purchase of the Creation Audio Labs, Inc. **MW1 STUDIO TOOL**. The sonic possibilities and creative solutions to several situations previously encountered in the recording and re-amplification of instruments can now be easily obtained. The MW1 Studio Tool is exactly that...a standard 19" 1 space rack unit that can allow the dutiful user to accomplish many functions that until now needed several separate items.

With ultra-high audio specs and very versatile routing and functionality, the MW1 Studio Tool will lend itself to be an indispensable addition to studios of all levels, broadcast applications, and even in live touring rigs. The MW1 Studio Tool can be installed in a rack or used as a stand alone unit for desk top interfacing to mixers, amps, and computer based systems.

The MW1 Studio Tool essentially addresses a long standing problem of how to get instrument levels up to line (pro) levels...and from pro back down to instrument levels...all in the same unit and without losing signal quality and tone. The transformerless DI section of the MW1 alone is a very pristine output that will be a feature of note and much use. Tracking of instruments DI simultaneously with impressive tone shaping functions of variable input / output impedance and up to 30db of ultra clean boost is now at your fingertips. Use pro studio gear in front of your favorite amp... or, instrument level pedals can be used on recorded tracks. A great way to paraphrase the function of the MW1 Studio Tool is to think of the unit as a "two way" signal router...UP to pro from instrument / DOWN from pro to instrument levels.

Please read the operations guide and review the quick reference sheet to help you best use the MW1 Studio Tool. With some careful experimentation and use, the functions and versatility of the unit will become very intuitive and will help you to achieve stellar results both on record and live. Contact Creation Audio Labs, Inc. at [www.creationaudiolabs.com](http://www.creationaudiolabs.com) for additional assistance.

Again, thank you for your investment in the MW1 Studio Tool and here's to your success.

CREATION AUDIO LABS, INC.  
MW1  
STUDIO TOOL

---

## **WARRANTY**

### **ONE YEAR WARRANTY**

Creation Audio Labs, Inc. will repair the MW1 STUDIO TOOL, free of charge, in the United States, in the event of faulty materials or workmanship for one (1) year from the date of purchase. This warranty is extended only to the original purchaser. Proof of purchase will be the responsibility of the owner, and registration of the product is highly recommended. Please register at [www.creationaudiolabs.com](http://www.creationaudiolabs.com). This limited warranty covers failures due only to defects in materials and workmanship that occur during normal, intended use and does not cover damage occurring in shipment of the product or failures which are caused by other products or misuse. This limited warranty does not cover failures which arise from accident, abuse, misuse, neglect, mishandling, faulty installation, improper adjustment, line power surges, modification, alteration, or service performed by anyone other than Creation Audio Labs, Inc. or its authorized agent.

Shipping charges to Creation Audio Labs, Inc. will be the responsibility of the owner of the product. Return shipping via the most economical means will be covered by Creation Audio Labs, Inc. Any expedited or special handling shipping requirements will be the responsibility of the owner, minus the charges that would be incurred by standard shipping rates for the return of the product.

### **LIMITS AND EXCLUSIONS**

There are no express warranties except as listed above. Creation Audio Labs, Inc. shall not be liable for special, incidental, subsequent, consequential, or punitive damages, including but not limited to: damage to any other equipment, damage to recordings, broadcasts, or live events, downtime costs, loss of goodwill, or claims of any party dealing with the purchaser for such damages resulting from the use of this product. All warranties, express and implied, including warranties of merchantability and fitness for a particular purpose are limited to the applicable warranty period set forth above.

CREATION AUDIO LABS, INC.  
MW1  
STUDIO TOOL

---

**SERVICE**

In the event of a problem with the MW1 STUDIO TOOL, contact CREATION AUDIO LABS, INC. at

**615-884-7520**

or

[generalinfo@creationaudiolabs.com](mailto:generalinfo@creationaudiolabs.com).

Creation Audio Labs, Inc. will issue a **RETURN AUTHORIZATION NUMBER** that will be used to keep track of the unit and the repair process. Creation Audio Labs, Inc. will make every effort to complete the service and return the unit as quickly as possible. An explanation of the problems encountered and the circumstances of how the unit was being used at the time of the malfunction should be included with the unit to facilitate the repair.

The shipping costs for the send and return of the unit will be the responsibility of the owner for out-of-warranty units, and will follow the guidelines for in-warranty units as outlined in the warranty section.

Any service work performed by unauthorized service centers or personnel will void the warranty, and Creation Audio Labs, Inc. will not be responsible for problems caused by unauthorized service.

There are absolutely **NO USER SERVICEABLE PARTS OR ADJUSTMENTS ON THE INSIDE OF THE MW1 STUDIO TOOL UNIT**. The risk of electrical shock hazard is present on the inside of the MW1 Studio Tool (as with all electronic devices) and therefore the lid should not be removed under any circumstances except by qualified and authorized service personnel. Any time the lid is removed the electrical power cable should be removed first to avoid electrical shock hazard.

## SAFETY PRECAUTIONS

**WARNING:** To reduce the risk of injury, the user must read and understand the operator's manual before using this product.

**WARNING:** There are absolutely **NO USER SERVICEABLE PARTS OR ADJUSTMENTS INSIDE OF THE MW1 STUDIO TOOL**. The lid should never be removed for any reason except by qualified and authorized service personnel.

**WARNING:** The MW1 Studio Tool **MUST** be connected to an **AC MAINS** outlet with a third pin **SAFETY GROUND** connected to earth.

**WARNING:** **RISK OF ELECTRICAL SHOCK INSIDE OF UNIT.** Never remove the lid of the MW1 STUDIO TOOL. All service issues must be addressed by qualified and authorized personnel. **ALWAYS DISCONNECT THE AC POWER CABLE BEFORE** removal of the lid and before any service is conducted on the unit.

Never use the MW1 STUDIO TOOL in dangerous environments.

Never use the unit with improper AC power cables or where unspecified power conditions are present.

Never replace the fuse with any fuse rated above or below the specified rating: 0.5A (5x20mm, slow-blow, 250V)

Do not expose the MW1 STUDIO TOOL to rain, moisture, or excessive amounts of cleaning solutions.

Do not allow excessive weight to be placed on the unit.

Allow adequate ventilation space when used in a rack or as a table-top unit.

Use reasonable care and common sense when using the MW1 STUDIO TOOL or any other piece of electronic equipment to obtain long lasting and satisfactory results.

## SPECIFICATIONS

### General:

Overall Signal Path, Instrument level input to instrument level output with line level out looped to line level in. No boost – No attenuation

Frequency Response:	< +/- 0.1 dB	20Hz – 20Khz	Typical
THD + Noise:	< 0.0015%	20Hz – 20Khz	Average
Noise Floor:	< -100dBu	20Hz – 20Khz	Average
Phase Response:	< +/- 1.0 degree	20Hz – 20Khz	Typical

Maximum Input or Output at ¼” jacks:	+22dBu	Typical
Maximum Input or Output at XLR jacks:	+28dBu	Typical

XLR are pin 2 hot

### Electro Mechanical:

Power Consumption:	20watts, nominal
Power Requirements:	100VAC to 240VAC 0.5A max 50-60Hz
Fuse:	0.5A (5x20mm, slow-blow, 250V)
Dimensions:	17” x 9” x 1 Standard Rack Unit
Net Weight:	Approx. 6 lbs

CREATION AUDIO LABS, INC.  
MW1  
STUDIO TOOL

---

## OVERVIEW

- Record DI and amp tracks simultaneously. (Fig. 3)
- Transformerless DI with no sound coloration. (Fig. 4)
- Variable input and output impedance.
- 0 – 30dB of pure clean boost. (Fig. 2)
- Mute function for silent tuning or changing instruments.
- Tuner outputs always active.
- Signal splitting to multiple amps. (Fig. 8)
- Re-amplification of pre-recorded tracks. (Fig. 5 & Fig. 9)
- Record tracks at low volume using plug-ins, DI, interfaces, or small amps, then re-amplify at high volumes when appropriate. (Fig. 5)
- Layering of tracks using different amps.
- Pro level units in front of amplifiers. (Fig. 6)
- Instrument level effects and guitar pedals can be used on pre-recorded tracks during mix. (Fig. 7)
- Ground lift switches to help eliminate noise.
- Illuminated back panel for easy identification of inputs and outputs.
- Rack mountable or can be used on the desk top.

# QUICK REFERENCE DIAGRAM

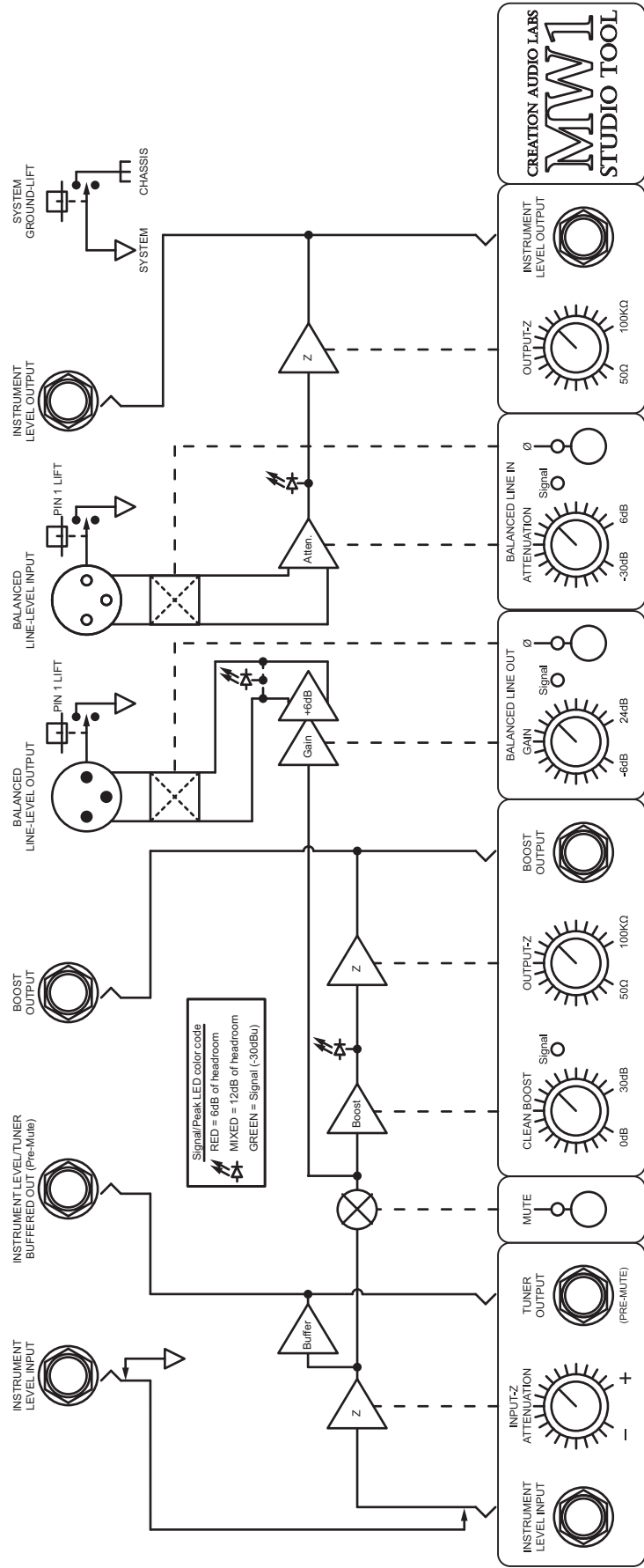

FIG. 1

# BOOSTED OUTPUT TO YOUR AMP

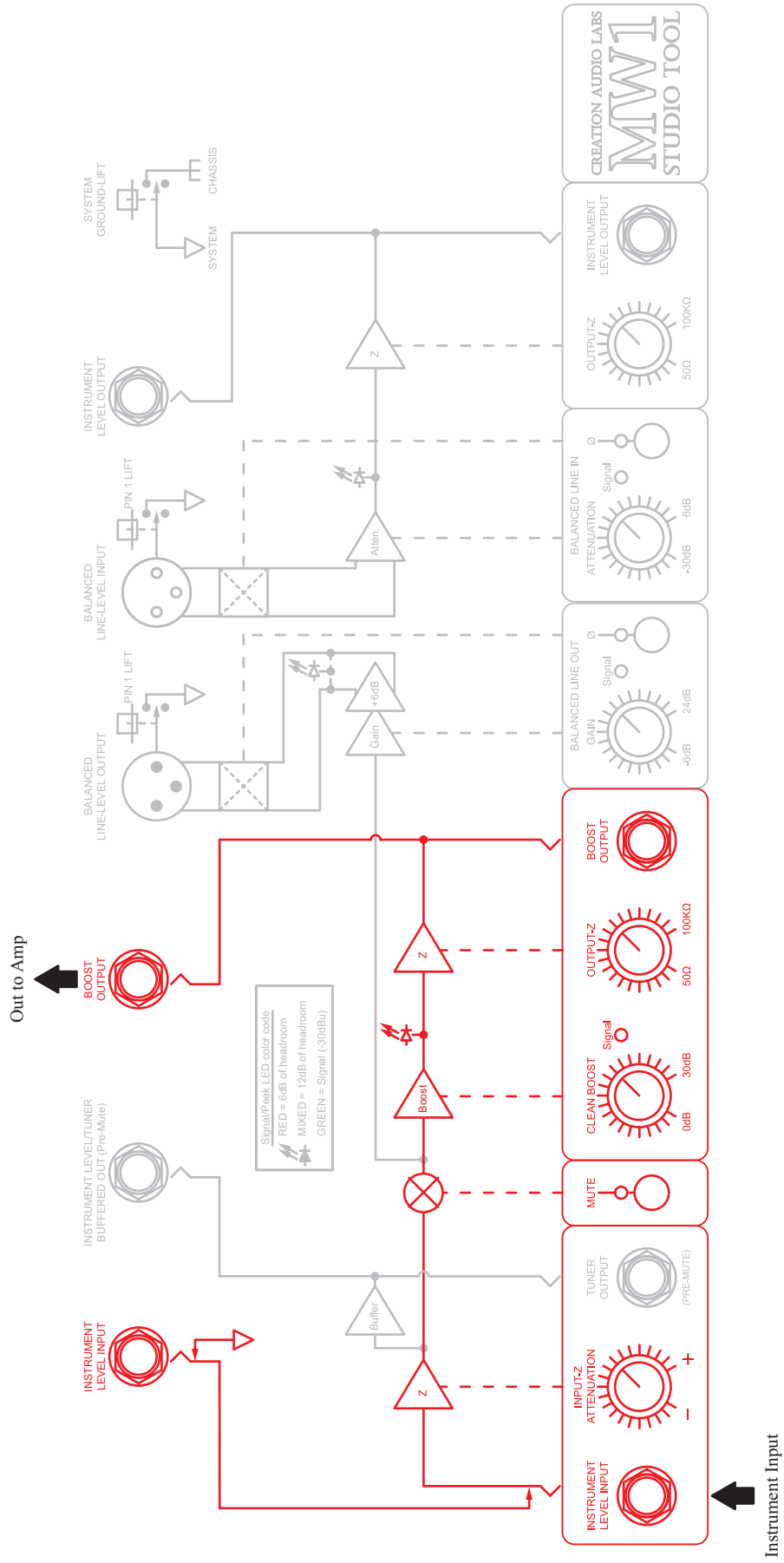

FIG. 2

RECORD D.I. & AMP TRACKS AT THE SAME TIME

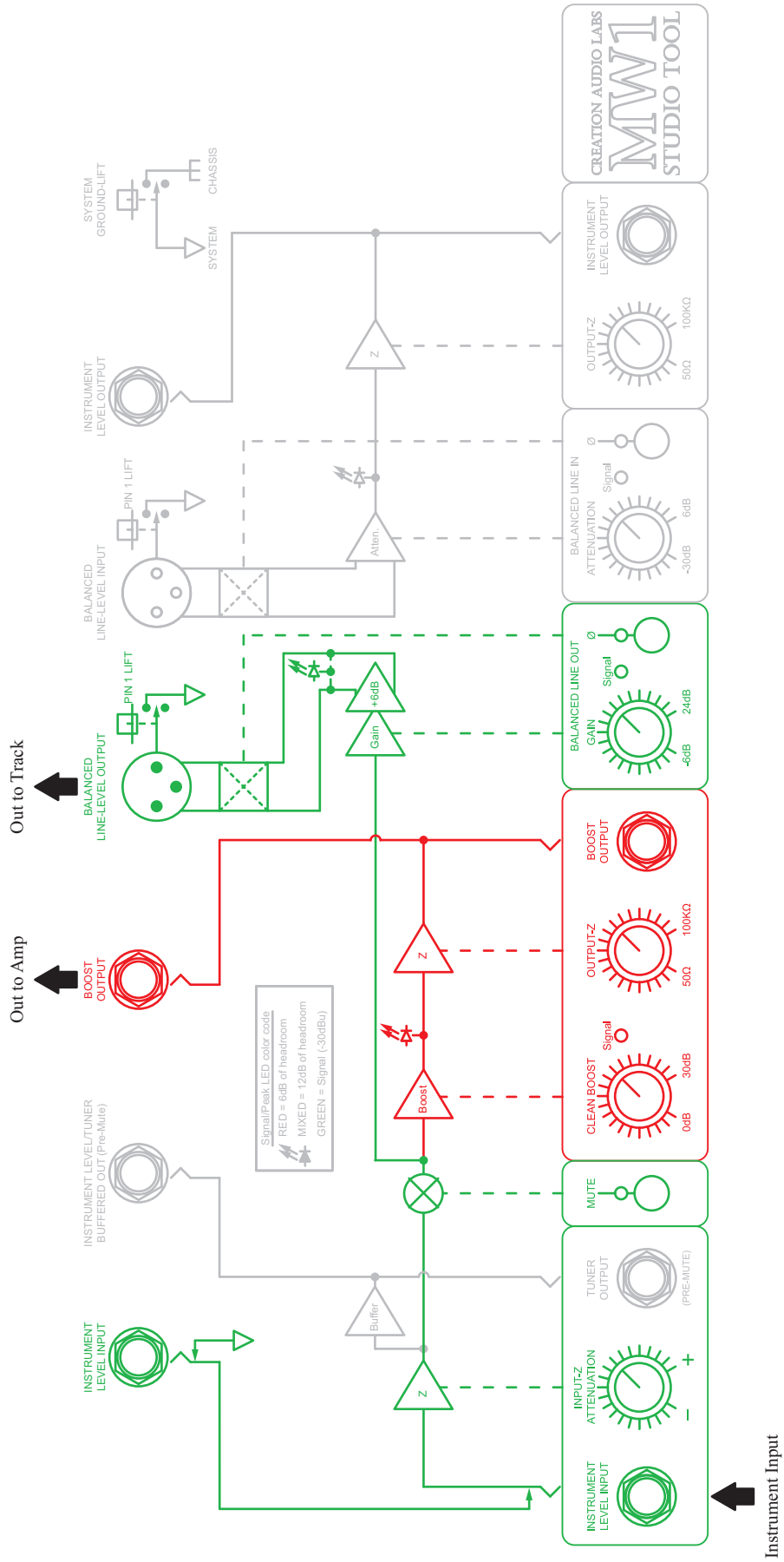

FIG. 3

USE AS A TRANSFORMERLESS INSTRUMENT LEVEL D.I.

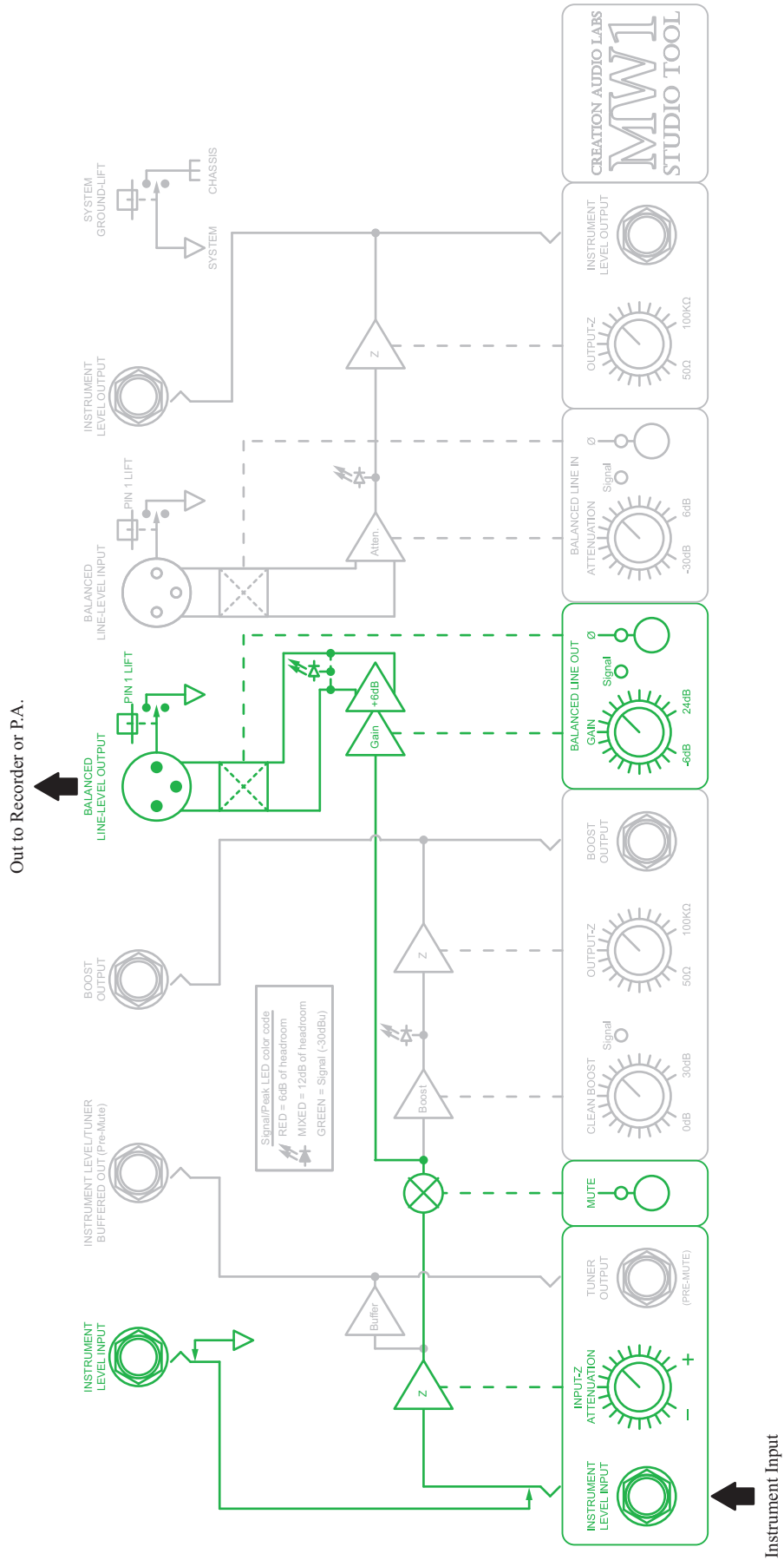

FIG. 4

# USE FOR REAL-AMPING AND RE-AMPLIFYING

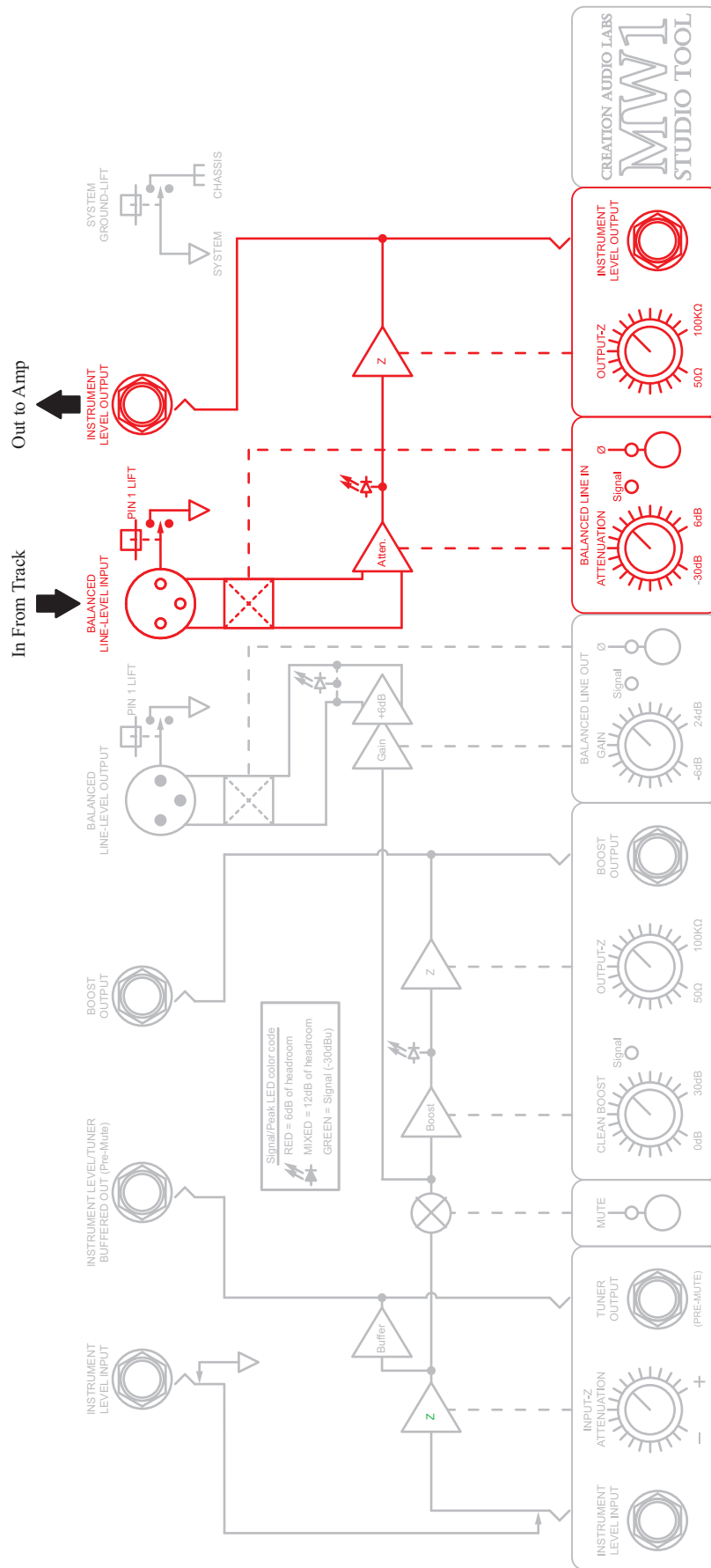

FIG. 5

# USE PRO STUDIO GEAR IN FRONT OF YOUR AMP

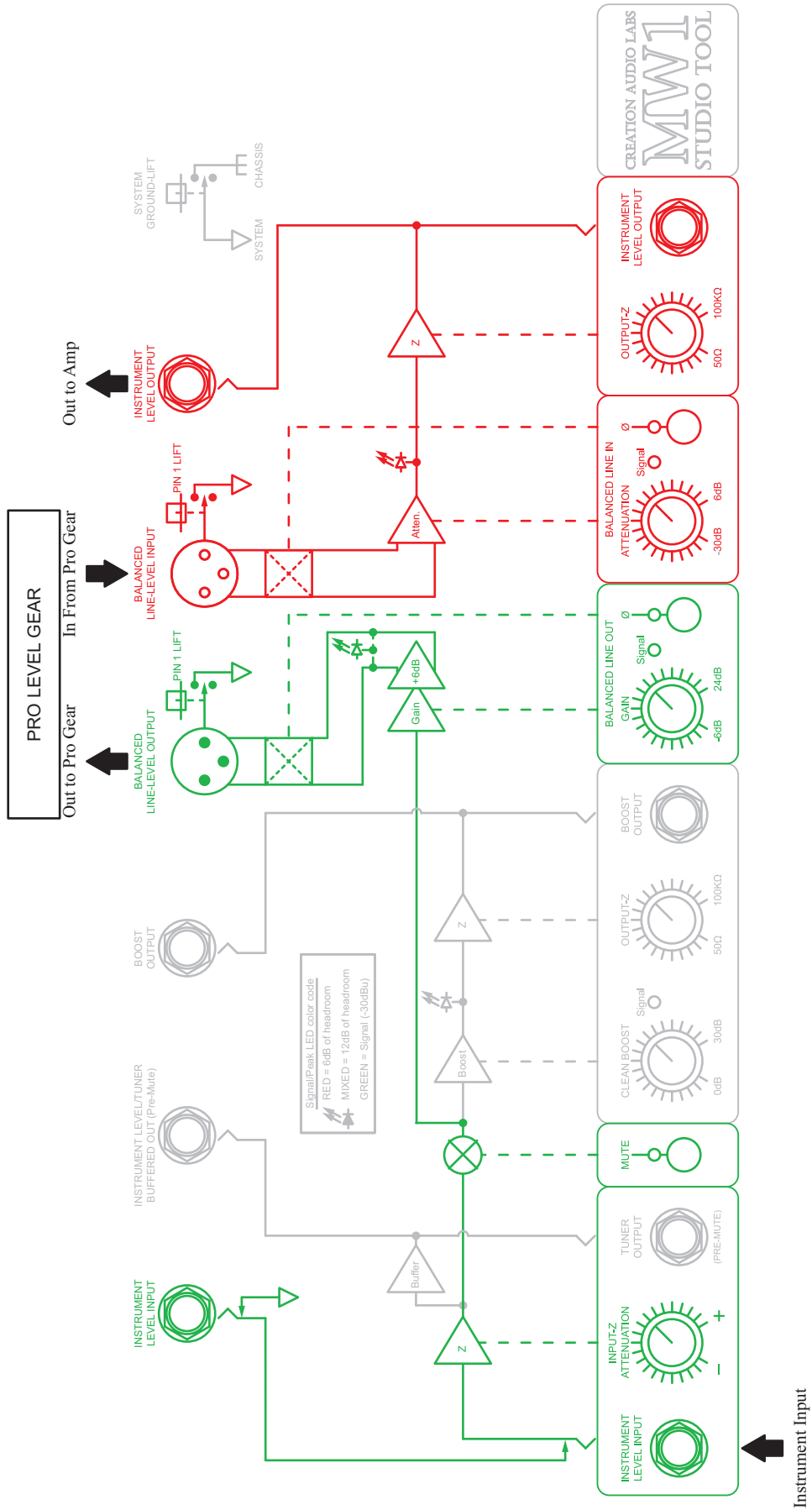

FIG. 6

# USE STOMP BOXES AS EFFECTS DURING MIX

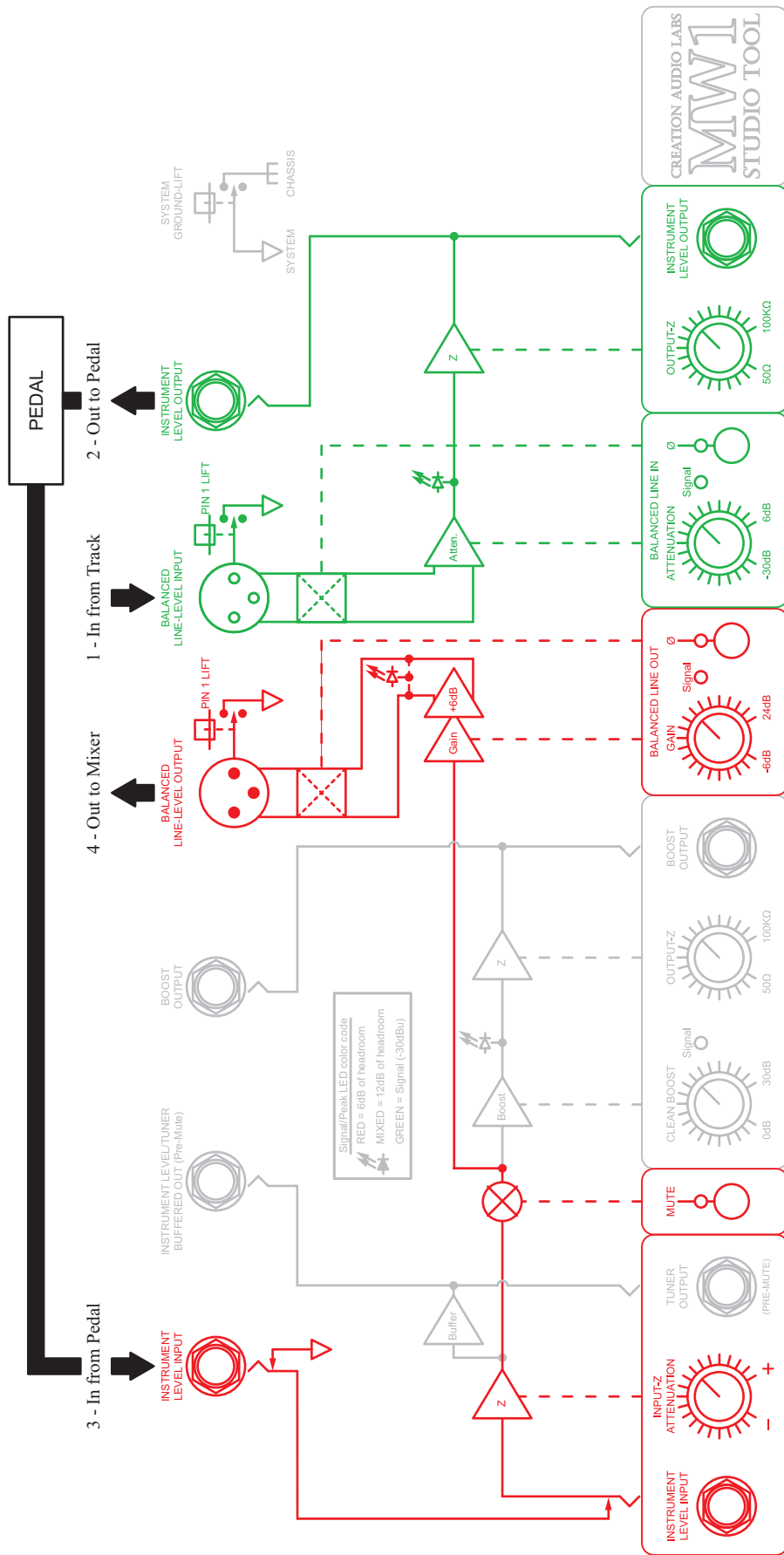

FIG. 7

# SPLITTING TO MULTIPLE AMPS

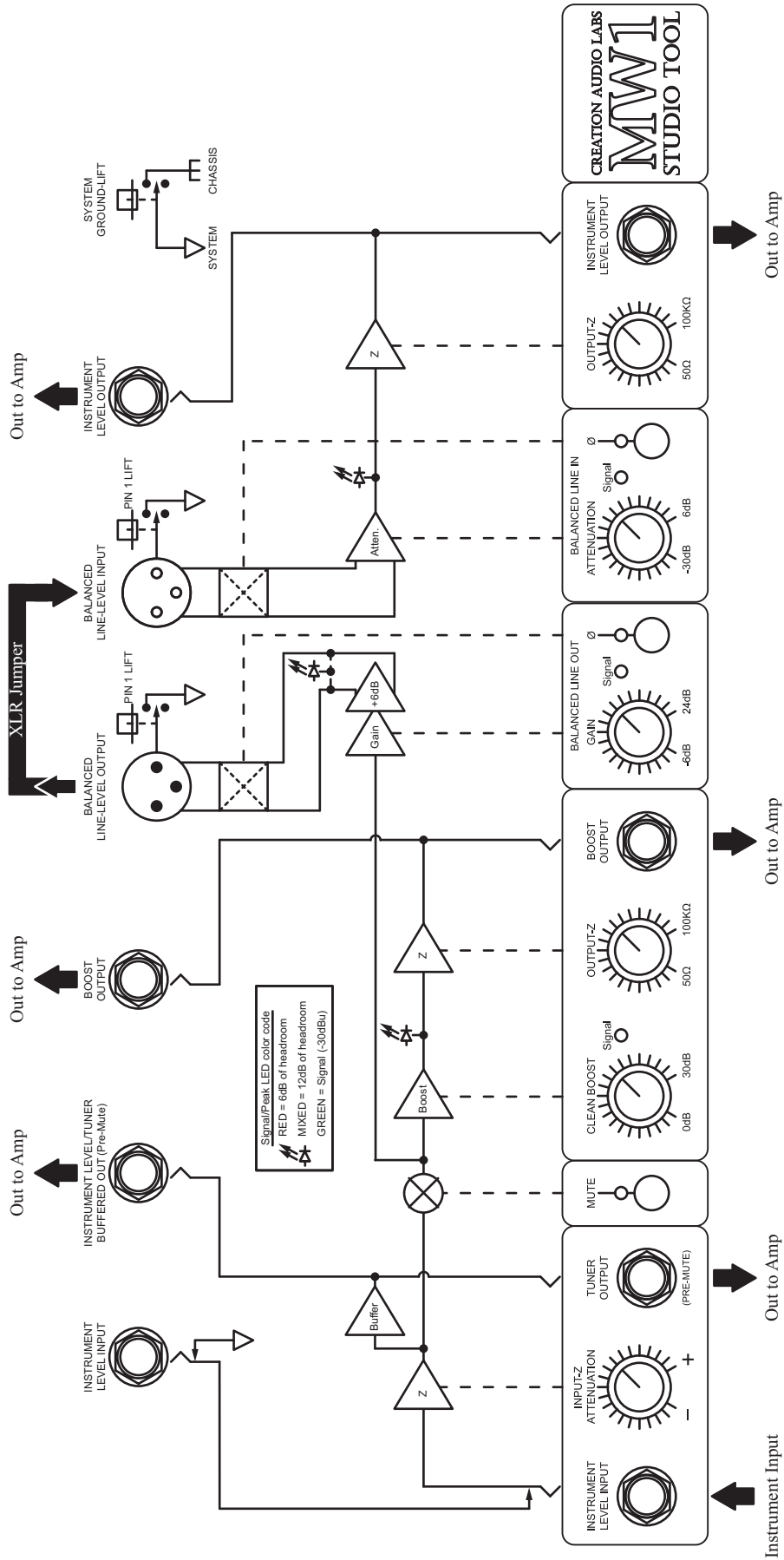

FIG. 8

# DELUXE REAL-AMPING

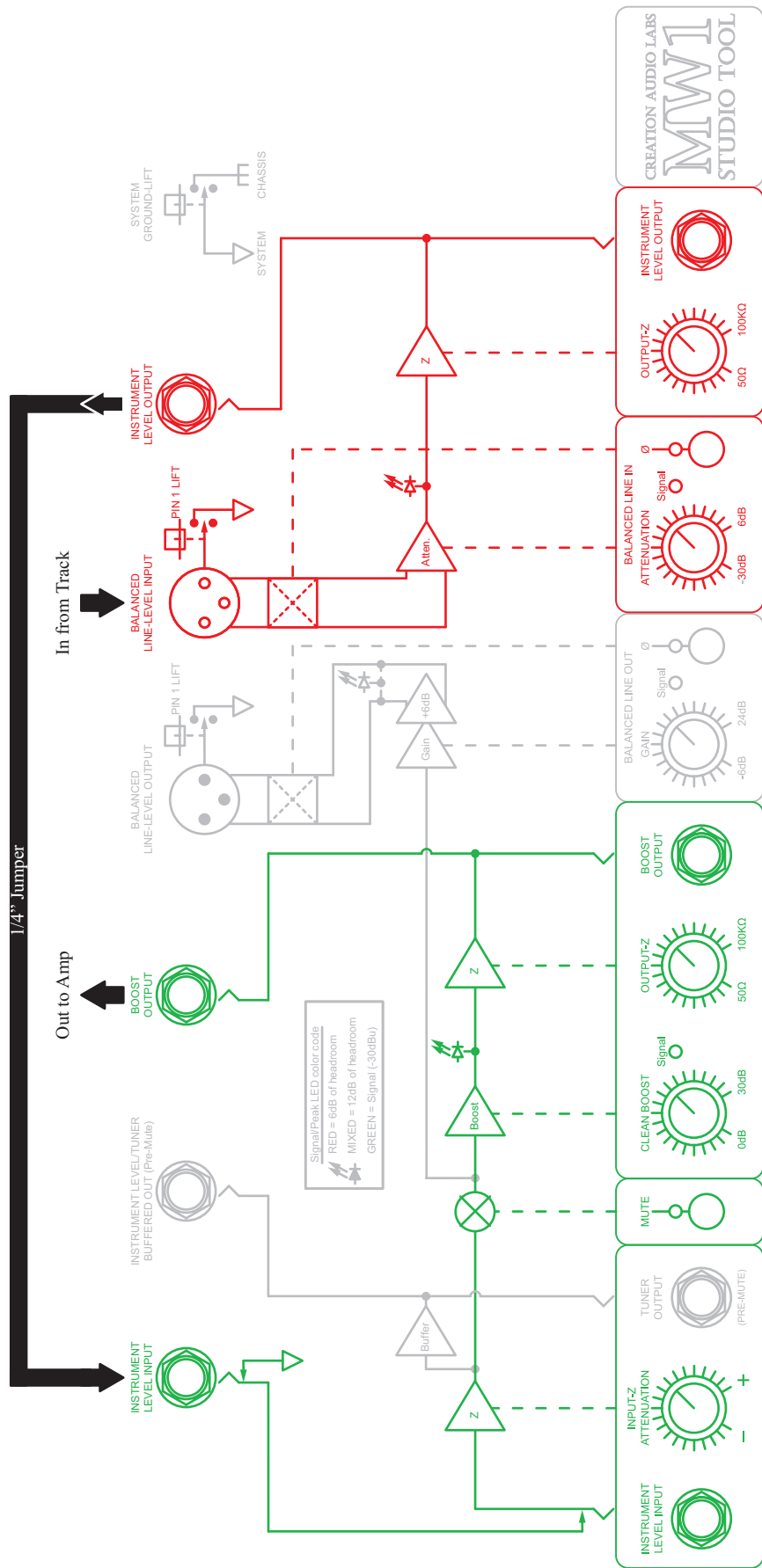
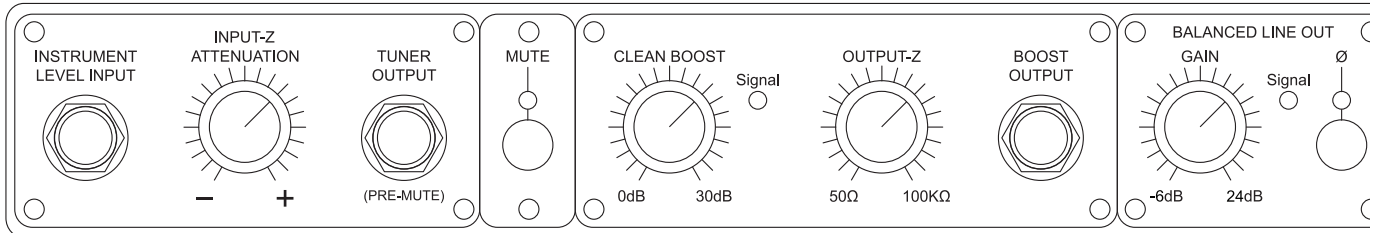

FIG. 9

# MW1 STUDIO TOOL

## QUICK REFERENCE

### FRONT PANEL: (left to right)



\*\*\*Please note that all front panel inputs and outputs are duplicated on the back panel. The XLR connectors appear only on the rear panel.

The first half of the MW1 Studio Tool constitutes what could be termed the **“GOING TO”** section of the unit. All of these functions allow tone shaping and going from instrument levels **up** to line levels.

- **INSTRUMENT LEVEL INPUT** 1/4" input for introducing signal to the MW1 Studio Tool from low level sources such as guitars, bass, keyboards, etc.
- **INPUT-Z ATTENUATION** This control allows the user to adjust the input impedance of the MW1 Studio Tool. In general terms, the (+) side of the control will equate to a brighter sound and the (-) side will become considerably darker and warmer. It must be noted that the INPUT-Z ATTENUATION control has direct influence on the sound of the BALANCED LINE LEVEL OUTPUT (DI output).
- **TUNER OUTPUT** 1/4" output jack allows for continuous tuner connection / operation. This is a buffered output that can also be used to output to amps or other equipment without loading the instrument's pickups. Useful for "splitting" the signal to multiple destinations. This output is pre-mute and therefore always active.
- **MUTE** The red MUTE button mutes the BOOST OUTPUTS and the BALANCED LINE LEVEL OUTPUT. This allows for tuning, changing of instruments, etc. When the MUTE button is depressed (engaged) the RED MUTE LED will be illuminated.
- **CLEAN BOOST** This control allows the user to boost the signal to the BOOST OUTPUT jack up to +30db. The CLEAN BOOST only deals with the BOOST OUTPUTS, and **does NOT** have any influence on the BALANCED LINE LEVEL OUTPUT (DI output).
- **CLEAN BOOST SIGNAL LED** This tri-color LED provides the following indications:

GREEN: Signal present (-30dBu)  
 MIXED: 12dB of headroom  
 RED: 6dB of headroom

- **OUTPUT-Z** The output impedance of the BOOST OUTPUT is adjusted with this control. Typically, the **lower** this setting the **better** matched the output impedance to the following equipment. In some cases a desired “warming” effect is achieved by turning the Output-Z control clockwise. This OUTPUT-Z is part of the “boost” section and only has effect on the BOOST OUTPUTS. The BALANCED LINE-LEVEL OUTPUT (DI output) is **NOT** influenced by this adjustment.

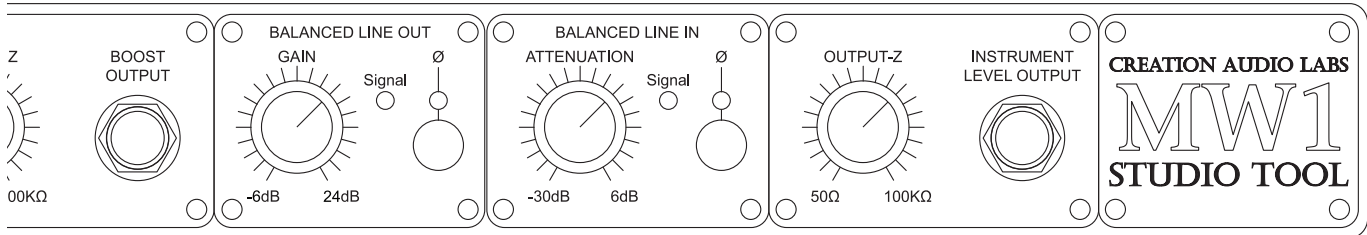

- **BOOST OUTPUT JACK** T 1/4” output jack for routing of signal to amps or other devices.
- **BALANCED LINE OUT GAIN** This control allows for -6dB to 24dB of gain for the BALANCED LINE-LEVEL OUTPUT (DI output, male XLR on the rear panel).
- **BALANCED LINE OUT SIGNAL LED** same as Clean Boost Signal LED.
- **BALANCED LINE OUT PHASE REVERSAL** This RED push button switch flips the polarity of the BALANCED LINE-LEVEL OUTPUT (DI out) by 180 degrees. Self explanatory, and very useful especially with older gear and when used for effect. The **NORMAL** polarity position is button out / LED off. The RED LED will illuminate when the switch is engaged and the polarity is reversed.

The next section of controls will address what can be called the “**COMING FROM**” section that deals with bringing line (pro) levels **down** to instrument levels.

- **BALANCED LINE IN ATTENUATION** This control allows for “attenuation” of pro level signals. In the -30dB position the incoming signal is “cut” down by 30dB.
- **BALANCED LINE IN SIGNAL LED** same as Clean Boost Signal LED.
- **BALANCED LINE IN SIGNAL POLARITY REVERSAL** Switches the polarity by 180 degrees on the incoming signal. Switch and LED operation as previously described.
- **OUTPUT-Z** Adjustment of the output impedance of the INSTRUMENT LEVEL OUTPUT. Typical “best case” scenarios will be at the 50ohm (full left / counter clockwise) setting, but again a clockwise turn of the knob can achieve a desired “warming” effect.
- **INSTRUMENT LEVEL OUTPUT** 1/4” output jack is used to connect the MW1 Studio Tool output to an amplifier or other device.
- **ON / OFF SWITCH** Switch will illuminate when the MW1 Studio Tool is powered on.

## BACK PANEL: (left to right)

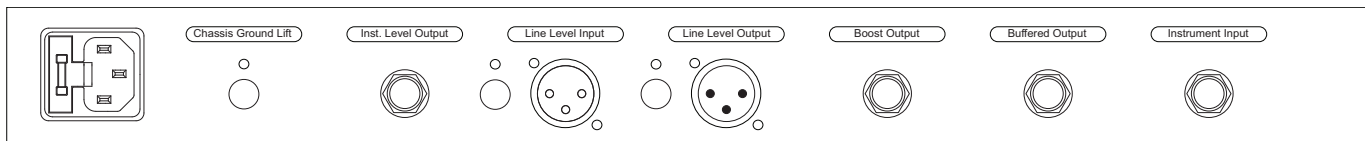

\*\*\*All 1/4" jacks are duplicates of the respective front panel 1/4" jacks and with the exception of the input jack, are active at the same time.

- **AC POWER CONNECTOR** Allows connection of power cable and incorporates a 5x20mm 500mA slow-blow MAINS fuse. The built-in universal power supply automatically accommodates any voltage from 90VAC up to 250VAC 50 or 60 Hz.
- **CHASSIS GROUND LIFT** When in the depressed position, the chassis ground is lifted from the MW1 Studio Tool audio reference. Use to help eliminate hum when connected to other gear that causes ground loops. When the ground is lifted the RED LED will be illuminated.

**NOTE:** Chassis is always connected to AC third pin ground for safety requirements.

- **INSTRUMENT LEVEL OUTPUT JACK** 1/4" output jack for routing instrument level signal to amps, stomp boxes or other devices.
- **LINE LEVEL INPUT PIN 1 LIFT** This RED button switch and corresponding RED LED is located to the left of the LINE LEVEL INPUT XLR/F connection. When engaged (depressed) this switch lifts PIN 1 of the XLR to help eliminate ground loops through the XLR connection.
- **LINE LEVEL INPUT XLR/F CONNECTION** Balanced Line Level signals from a pro source (console, recorder, converter, pro rack unit, etc.) are routed into the MW1 Studio Tool via this input XLR/F jack.
- **LINE LEVEL OUTPUT PIN 1 LIFT** This RED button and LED is located to the left of the LINE LEVEL OUTPUT and operates as previously described.
- **LINE LEVEL OUTPUT** The XLR/M output jack is the BALANCED LINE-LEVEL OUTPUT and is a very accurate and pristine DI output that can be used in many ways. As a straight forward transformerless DI this output is extremely useful for recording clean guitar, bass, keyboards, or any instrument requiring a step up to line level.
- **BOOST OUTPUT JACK** 1/4" output jack for routing of signal to amps or other instrument level devices.
- **BUFFERED OUTPUT** This 1/4" output jack allows for continuous tuner connection / operation. This is a buffered output that can also be used to output to amps or other equipment.
- **INSTRUMENT LEVEL INPUT** 1/4" input for introducing signal to the MW1 Studio Tool from low level sources such as guitars, bass, keyboards, etc.

CREATION AUDIO LABS, INC.  
**MW1**  
**STUDIO TOOL**

## DETAILED OPERATION

As briefly noted in the Introduction and Quick Reference sections, the MW1 STUDIO TOOL should be viewed as a unit that has two **general** signal path functions. The MW1 Studio Tool can take instrument level signals **UP** to line (pro) levels, and line level signals **DOWN** to instrument levels at the same time, and with no signal degradation or tone loss. Once an understanding of these basic signal flow principles is fully understood the operation of the MW1 Studio Tool will be very intuitive and will allow the user to obtain excellent results for a number of situations both live and in the studio.

Looking at the MW1 Studio Tool from left to right, the left 2/3 of the unit would be generally considered to be the **“GOING TO”** section. Basically, instrument level signal is “going to” other destinations such as tuners, amplifiers, and **UP** to line level via the XLR output. This portion of the MW1 Studio Tool offers a tremendous amount of signal routing flexibility and tone shaping capability. Each of the controls provides a unique signal function individually and when used together the vast tone shaping options and solutions come to life.

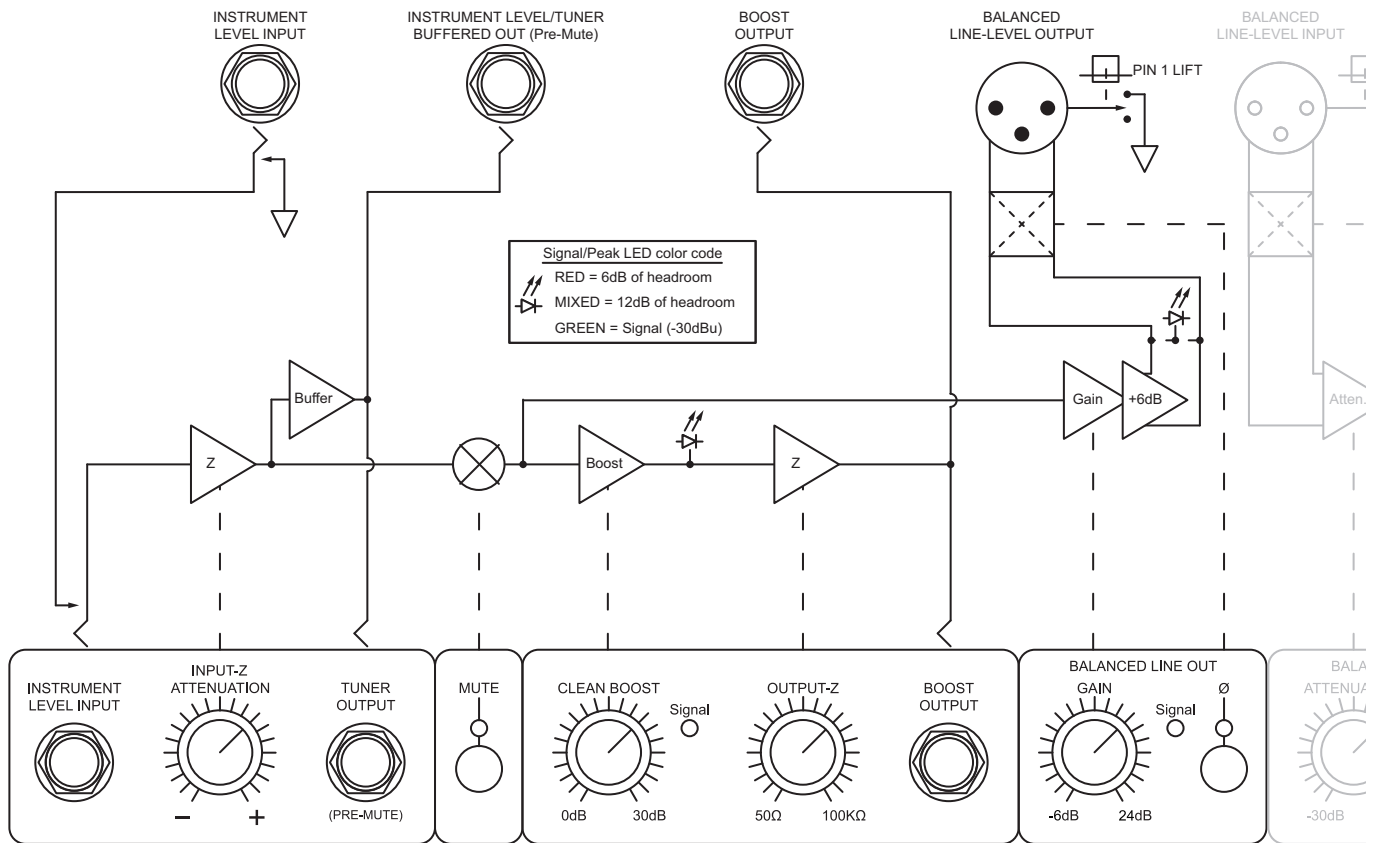

\*\*\*All 1/4” jacks are duplicated on the front and back of the MW1 Studio Tool. With the exception of the **INSTRUMENT LEVEL INPUT** connections, all 1/4” jacks front and back will be active at the same time. As such, the duality of the output jacks allows for multiple signal path routing. The **front INSTRUMENT LEVEL INPUT** takes priority over the rear input.

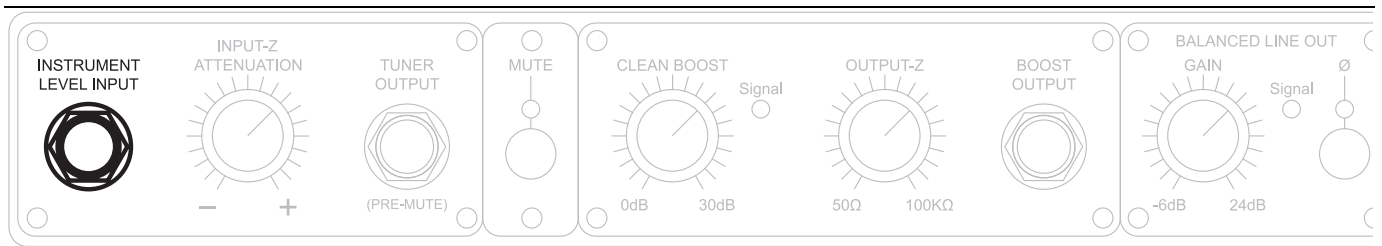

- INSTRUMENT LEVEL INPUT** ¼” input for introducing signal to the MW1 Studio Tool from low level sources such as guitars, bass, keyboards, etc. Additionally, when the MW1 Studio Tool is being used to place a low level device such as a guitar flanger pedal across a previously recorded track the **output of the pedal** would be connected to this input on the MW1 Studio Tool (see Fig. 7 of the Quick Reference Sheet). This input is unbalanced.

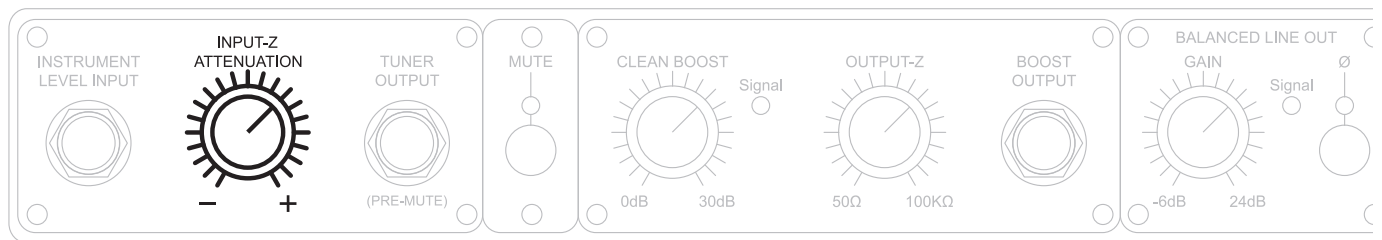

- INPUT-Z ATTENUATION** This control allows the user to adjust the input impedance of the MW1 Studio Tool. In general terms, the + side of the control will equate to a brighter sound and the – side will become considerably darker and warmer. This is a very versatile tone shaping function as the impedance relationship of instruments to other equipment is an incredibly big deal. Here’s why:

Especially with passive instruments such as guitars, basses, steel guitars, keyboards that employ pickups, and other “pick-up” based instruments, an “electronic math equation” is developed upon plugging in the instrument. Now there is a connection from the pickup, through any onboard volume and tone controls (usually pots and capacitors), along the cable and eventually to the input of the following device. The relative impedance of the pickup, the capacitance of the cable, and the relative impedance of the “thing” we plug **into** creates an electronic pathway that the signal from the instrument “**rides**” along.

Depending on all of these factors:

- Impedance of the instrument’s pickup(s) (varying from 4K on singles to 16K on humbuckers, + or -)
- Values of the instrument’s volume and tone pots / caps and **their relative positions up or down**
- Length and overall capacitance of the connection cable
- The impedance of the device that the instrument is being plugged **into**, be it a pedal, amp, etc.

A condition or “equation” is created that determines how well the instrument’s signal can travel along the connection.

So it is easy to determine that this “equation” is ever varying and cannot be relegated into a standard that works in all cases and at all times. Change any of the variables and a change will occur in regard to the tone of the instrument...sometimes very drastic and other times minimally. Essentially, the pickup’s effectiveness is being determined by factors along the entire connection.

In general terms, pickups like to see very **HIGH** impedances relative to their own impedance. This holds true for all output to input relationships: outputs low impedance to inputs high impedance. The higher the input impedance that the pickup is dealing with, the **lower the load** of COUNTER ELECTRO-MAGNETIC FORCE the pickup has to overcome to deliver signal. Indeed, a bit confusing, but suffice it to say that the higher the input impedance of the pedal or amp is, the better.

If the input impedance of the amp or pedal is relatively low, the pickup will become **loaded** and the instrument’s signal spectrum will become attenuated. This directly relates to how well the signal can travel along the connection and (because impedance is also frequency dependent) dictates the quality of the instrument’s tone arriving at the next device.

This **high to low / unloading or loading** situation is what the **INPUT-Z ATTENUATION** control deals with. At the (-) position the input impedance of the MW1 Studio Tool will be **low** (less than 10K ohms) as viewed from the pickup’s perspective. This means the pickup will be **loaded** and will have attenuated signal spectrum. This equates to a very dark and warm tone with minimal high frequency response.

With the **INPUT-Z ATTENUATION** control set to the (+) position, the input impedance of the MW1 Studio Tool will be very high (greater than 10M ohms) relative to the pickup resulting in **unloading** of the EMF felt by the pickup, better signal development, and better fidelity overall. The pickup will be better able to deliver wide bandwidth frequency response that will include the higher frequencies and greater detail. Harmonic content will be much more apparent. The full (+) position of this control would be considered to be the **most pristine** and it should be noted here, with special attention, that the **BALANCED LINE LEVEL OUTPUT (THE DI OUTPUT)** is influenced by this control.

#### INPUT-Z ATTENUATION:

(-) = Very dark and warm tone, heavy pickup loading, less high frequency response.

(+) = Very wide bandwidth response, pristine, unloading of the pickup, full harmonic content.

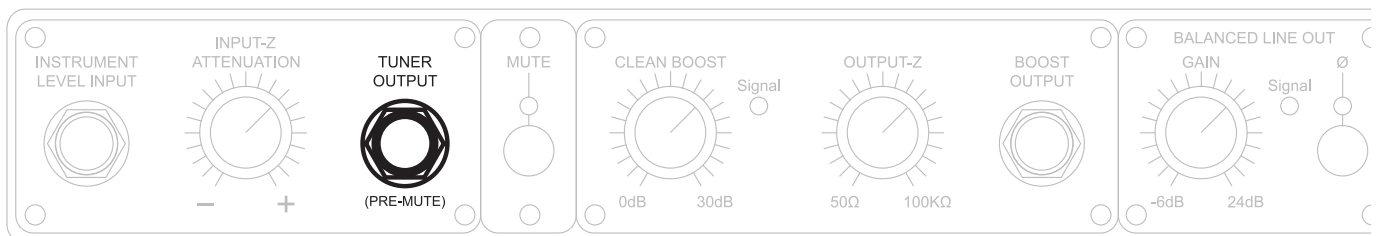

- **TUNER OUTPUT** This 1/4” output jack allows for continuous tuner connection / operation. This is a buffered output that can also be used to output to amps or other equipment without loading the instrument’s pickups. Useful for “splitting” the signal to

multiple destinations. This output is **pre-mute** and therefore always active. The TUNER OUTPUT also is directly affected by the INPUT-Z ATTENUATION control, and at very counter-clockwise (-) positions the signal from the instrument may be too low for the tuner to acquire a reading. In this event, temporarily raise the INPUT-Z ATTENUATION control until the tuner can sufficiently read the signal. After the instrument is tuned, readjust the INPUT-Z ATTENUATION back to the desired setting.

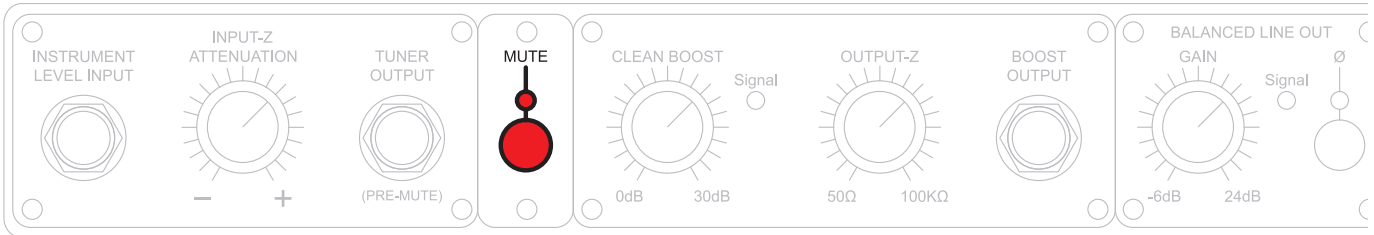

- **MUTE** The red MUTE button mutes the BOOST OUTPUTS and the BALANCED LINE LEVEL OUTPUT. This allows for tuning, changing of instruments, etc. When the MUTE button is depressed (engaged) the RED MUTE LED will be illuminated.

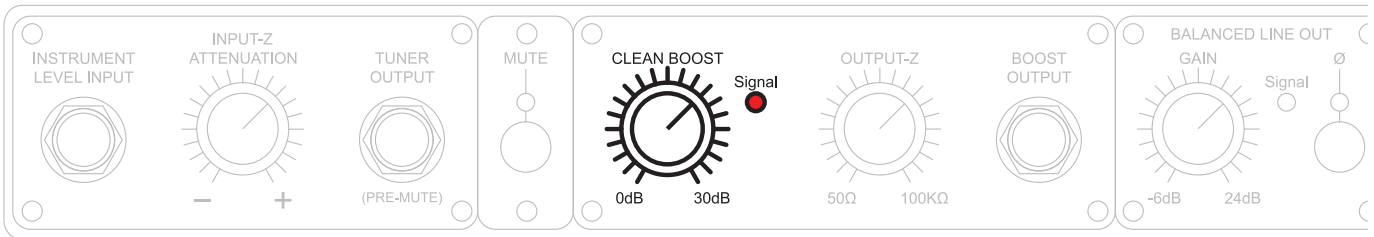

- **CLEAN BOOST** This control allows the user to boost the signal to the BOOST OUTPUT jacks by 30db. The CLEAN BOOST only deals with the BOOST OUTPUTS, and **does NOT** have any influence on the BALANCED LINE LEVEL OUTPUT (DI output).

The possibilities of this function of the MW1 Studio Tool are enormous. Totally **clean** boost up to +30dB can be employed to obtain a vast array of tones. Wide bandwidth, full, flat frequency response clean gain is a very useful tool. Most traditional gain circuits are somewhat frequency dependent, boosting only portions of the signal (usually the mids and highs). Often, an increase in gain means a corresponding increase of noise, not so with the MW1 Studio Tool.

The **CLEAN BOOST** control and corresponding **BOOST OUTPUT JACKS** provide a great way to add extra signal level to a following device or to really **overdrive** the front end of amplifiers. The capability of adding extra power to the signal has a big effect on the amplifier's response and tone.

When the **CLEAN BOOST** and **INPUT-Z ATTENUATION** controls are used in combination many different tone possibilities become apparent.

- **CLEAN BOOST SIGNAL LED** This tri-color LED provides the following indications:

GREEN: Signal present (-30dBu)  
 MIXED: 12dB of headroom  
 RED: 6dB of headroom

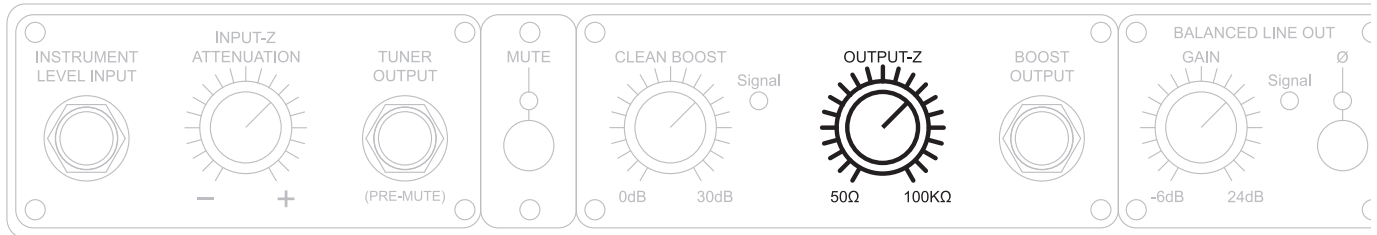

- **OUTPUT-Z** The output impedance of the BOOST OUTPUT is adjusted with this control. Typically, the **lower** this setting the **better** the output fidelity of the signal. This function usually does not have a drastic sonic change, but in a critical listening environment the effect can be heard, and sometimes, more **felt**. This control deals with the impedance from the MW1 Studio Tool to the amp or next device. Lower settings allow the MW1 Studio Tool to more efficiently drive longer or lower quality cables with better sonic quality. This OUTPUT-Z is part of the “boost” section and only has effect on the BOOST OUTPUTS. The BALANCED LINE-LEVEL OUTPUT (DI output) is **NOT** influenced by this adjustment.

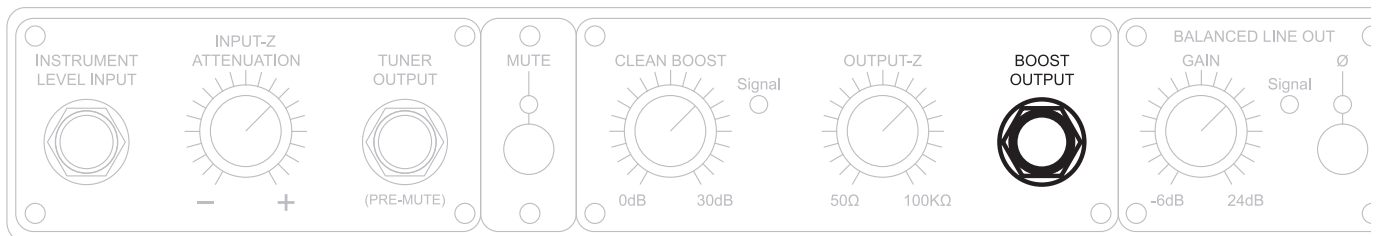

- **BOOST OUTPUT JACK** ¼” output jack for routing of signal to amps or other instrument level devices. This output is influenced by all previous controls. This would be the typical output run to an amp that in turn would be mic’d for tracking. Additionally, this output is stellar for a live situation where the above tone shaping functions may come in handy.

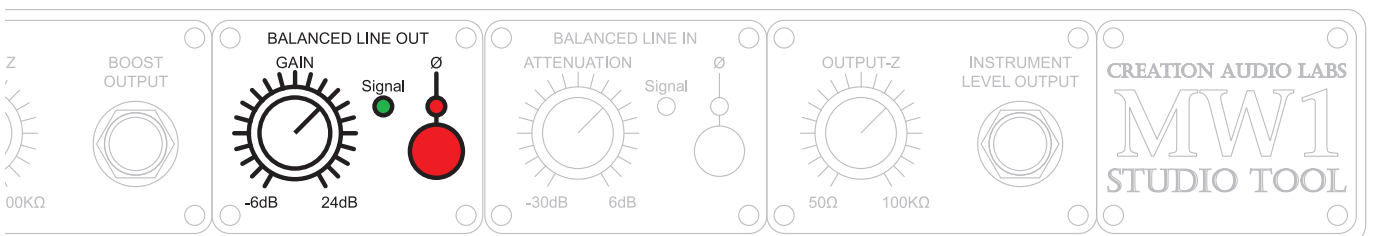

- **BALANCED LINE OUT GAIN** This control allows for -6 to +24dB of gain for the BALANCED LINE-LEVEL OUTPUT (DI output, male XLR on the rear panel). Additional gain can be added to smaller signals to better “fill up” recording “bits,” increase

the gain to pro-level units in the event of using a pro unit in front of a guitar or bass amp (i.e. Fig. 6 of the QUICK REFERENCE SHEET), or even to intentionally overdrive the input stage of the following unit. Remember that this control and the **INPUT-Z ATTENUATION** control have direct influence on the sonic signature of the **BALANCED LINE-LEVEL OUTPUT (DI output)**.

- **BALANCED LINE OUT SIGNAL LED** same as Clean Boost Signal LED.
- **BALANCED LINE OUT POLARITY REVERSAL** This RED push button switch flips the polarity of the **BALANCED LINE-LEVEL OUTPUT (DI out)**. Self explanatory, and very useful especially with older gear and when used for effect. The **NORMAL** polarity position is button out / LED off. The RED LED will illuminate when the switch is engaged and the polarity reversed.

The next section of controls will address what can be called the “**COMING FROM**” section that deals with bringing line (pro) levels **down** to instrument levels.

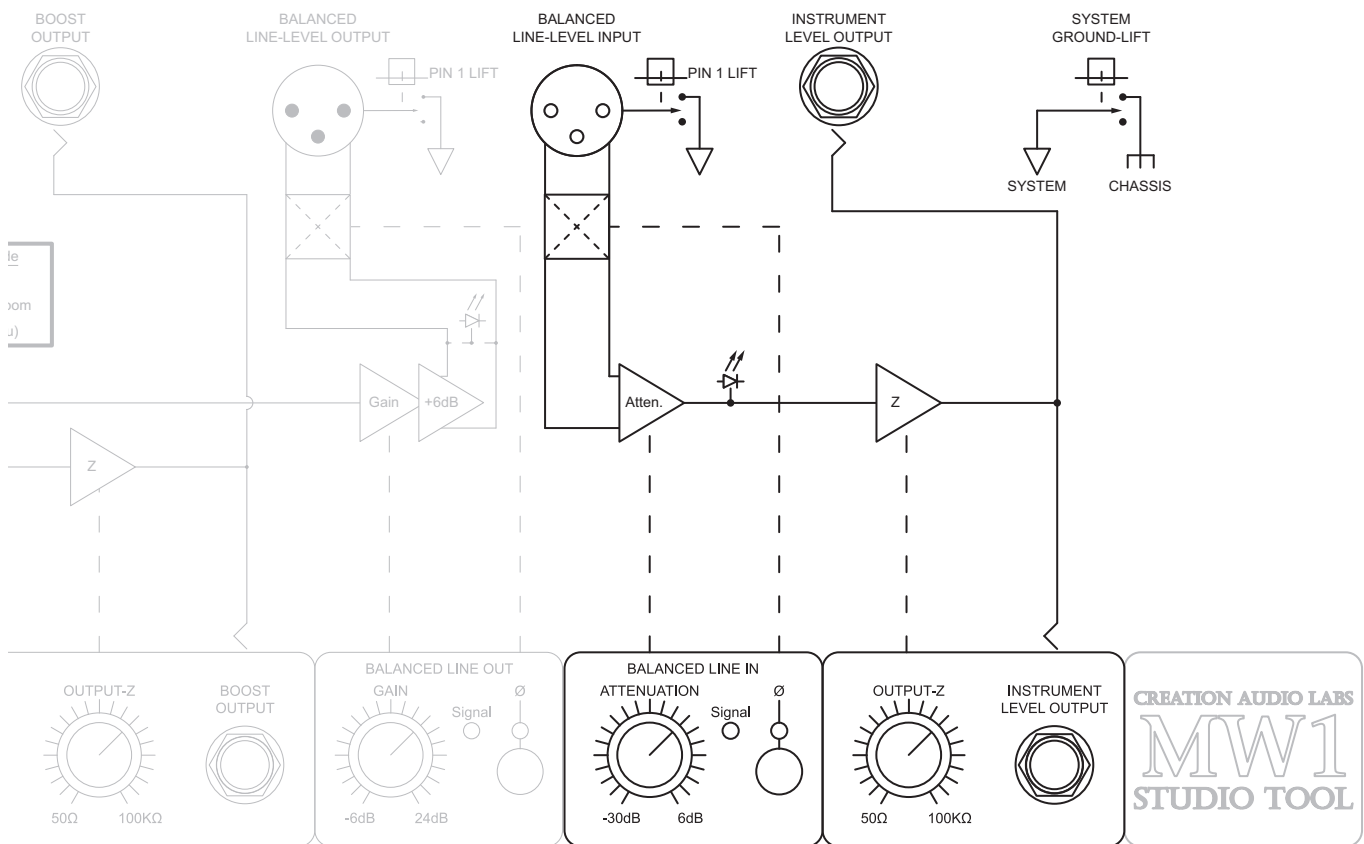

\*\*\*All ¼” jacks are duplicated on the front and back of the MW1 Studio Tool. With the exception of the **INSTRUMENT LEVEL INPUT** connections, all ¼” jacks front and back will be active at the same time. As such, the duality of the output jacks allows for multiple signal path routing. The **front INSTRUMENT LEVEL INPUT** takes priority over the rear input.

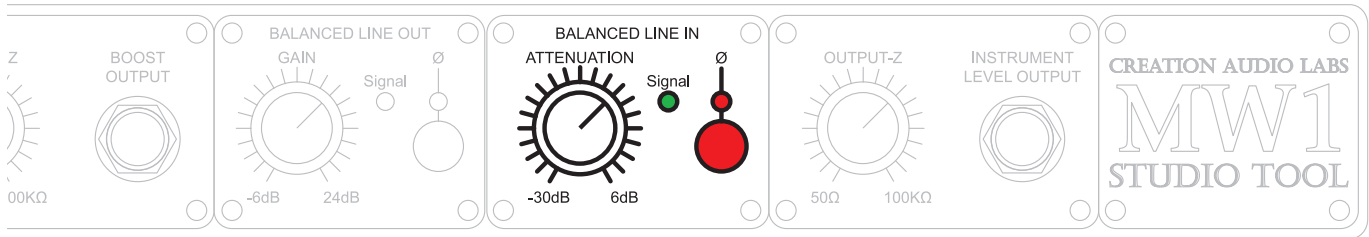

- **BALANCED LINE IN ATTENUATION** This control allows for “attenuation” of pro level signals, and receives signal from the **LINE LEVEL INPUT XLR/F** connection. In the -30dB position the incoming signal is “cut” down by 30dB. As the knob is rotated to the right, the signal is **less cut** and more of the original signal level is intact, which in turn means more output to the INSTRUMENT LEVEL OUTPUT jack. This comes into use especially for the re-amplification of previously recorded tracks (especially **DRY** tracks initially recorded with the MW1 Studio Tool). This adjustment will also play a big part in the assignment of a **pedal** effect being used for a recorded track...for instance using a guitar distortion pedal on a vocal.
- **BALANCED LINE IN SIGNAL LED** same as Clean Boost Signal LED.
- **BALANCED LINE IN SIGNAL POLARITY REVERSAL** Switches the phase 180 degrees on the incoming signal. Switch and LED operation as previously described.

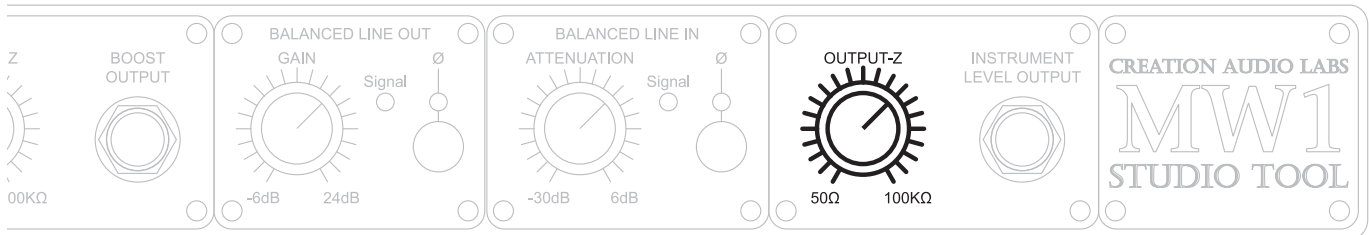

- **OUTPUT-Z** Adjustment of the output impedance of the INSTRUMENT LEVEL OUTPUT. This also is more or less effective based on the following equipment and is useful for driving long lines. Typical “best case” scenarios will be at the 50ohm (full left / counter clockwise) setting. Adjust this control for desired sonic result.

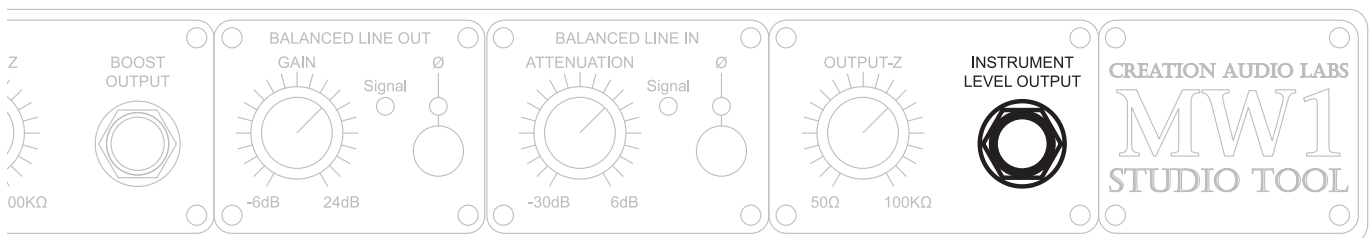

- **INSTRUMENT LEVEL OUTPUT** This ¼” output jack is used to connect the MW1 Studio Tool output to an amplifier or other device. This is the output that would be used for re-amplification of previously recorded tracks. Additionally, this output is the main output source for the “coming from” recorded track / line / pro level to instrument level setup. This output would also be routed to the input of a pedal when the pedal is being

used as an effect a “non-guitar” track such as a vocal or string track. (See Fig. 7 of the QUICK REFERENCE SHEET)

- **ON / OFF SWITCH** Switch will illuminate when the MW1 Studio Tool is powered on.

---

## BACK PANEL: (left to right)

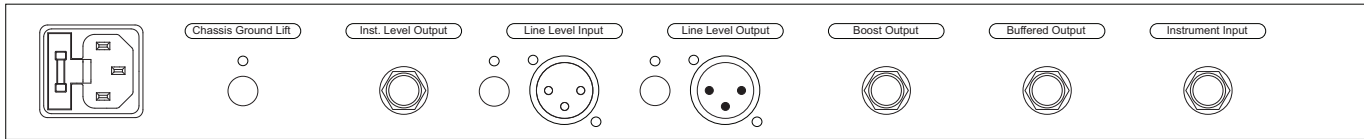

\*\*\*All ¼” jacks are duplicates of the respective front panel ¼” jacks and with the exception of the input jack, are active at the same time.

- **AC POWER CONNECTOR** Allows connection of power cable and incorporates a 5x20mm 500mA slow-blow MAINS fuse. The built-in universal power supply automatically accommodates any voltage from 90VAC up to 250VAC 50 or 60 Hz.
- **CHASSIS GROUND LIFT** When in the depressed position, the chassis ground is lifted from the MW1 Studio Tool audio reference. Use to help eliminate hum when connected to other gear that causes ground loops. When the ground lift is in place the RED LED will be illuminated.

**NOTE:** Chassis is always connected to AC third pin ground for safety requirements.

- **INSTRUMENT LEVEL OUTPUT JACK** ¼” output jack for routing instrument level signal to amps, stomp boxes or other devices (review Fig. 5-7).
- **LINE LEVEL INPUT PIN 1 LIFT** This RED button switch and corresponding RED LED is located to the left of the LINE LEVEL INPUT XLR/F connection. When engaged (depressed) this switch lifts PIN 1 of the XLR to help eliminate ground loops through the XLR connection.
- **LINE LEVEL INPUT XLR/F CONNECTION** Balanced Line Level signals from a pro source (console, recorder, converter, pro rack unit, etc.) are routed into the MW1 Studio Tool via this input XLR/F jack. This is the first item in the “coming from” aspect of the MW1 Studio Tool. Signal is then routed to the BALANCED LINE IN ATTENUATION function of the MW1 Studio Tool to facilitate the “pro level **down** to instrument level” portion of the unit.
- **LINE LEVEL OUTPUT PIN 1 LIFT** This RED button and LED is located to the left of the LINE LEVEL OUTPUT and operates as previously described.
- **LINE LEVEL OUTPUT** This is the last stage of the “going to” aspect of the MW1 Studio Tool. The XRL/M output jack is the BALANCED LINE-LEVEL OUTPUT and is a very accurate and pristine DI output that can be used in many ways. As a straight forward transformerless DI this output is extremely useful for recording clean guitar, bass, keyboards, or any instrument requiring a step up to line level. It should be noted that this

output is influenced by the INPUT-Z ATTENUATION control and will sound darker and warmer at the (-) settings. Additionally, the DI output will remain clean and unaffected by the positioning of the CLEAN BOOST, but the DI output responds to the BALANCED LINE OUT control. Refer to the overall schematic of the MW1 Studio Tool on the QUICK REFERENCE SHEET for clarification of the signal path (Fig. 1).

- **BOOST OUTPUT JACK** ¼” output jack for routing of signal to amps or other devices. This output is influenced by all previous controls. This would be the typical output run to an amp that in turn would be mic’d for tracking. Additionally, this output is stellar for a live situation where the above tone shaping functions may come in handy.
- **BUFFERED OUTPUT** This ¼” output jack allows for continuous tuner connection / operation. This is a buffered output that can also be used to output to amps or other equipment without loading the instrument’s pickups. Useful for “splitting” the signal to multiple destinations. This output is **pre-mute** and therefore always active. The BUFFERED OUTPUT also is directly affected by the INPUT-Z ATTENUATION control, and at very counter-clockwise (-) positions the signal from the instrument may be too low for the tuner to acquire a reading. In this event, temporarily raise the INPUT-Z ATTENUATION control until the tuner can sufficiently read the signal. After the instrument is tuned, readjust the INPUT-Z ATTENUATION back to its original setting.
- **INSTRUMENT LEVEL INPUT** ¼” input for introducing signal to the MW1 Studio Tool from low level sources such as guitars, bass, keyboards, etc. Additionally, when the MW1 Studio Tool is being used to place a low level device such as a guitar flanger pedal across a previously recorded track the **output of the pedal** would be connected to this input on the MW1 Studio Tool (see Fig. 7 of the Quick Reference Sheet).

CREATION AUDIO LABS, INC.  
MW1  
STUDIO TOOL

---

## **DECLARATION of CONFORMITY**

**We,**  
Creation Audio Labs, Inc.  
3668-B Central Pike  
Hermitage TN 37076

**declare that the following product:**

MW1 Studio Tool from serial #:1 and onwards

**is in conformity with the provisions of the following European Directives:**

Council Directive 2002/95/EC – (RoHS Directive)  
Council Directive 2002/96/EC – (WEEE Directive)  
Council Directive 2004/108/EC – (EMC Directive)  
Council Directive 2006/95/EC – (Low Voltage Directive)

**And the following standards:**

European Harmonized Standard  
EN60065:2001 (Audio, video and similar electronic apparatus. Safety requirements)  
EN50333:2001 (Routine Test for AC Equipment)  
EN55103-1:1996 (EMC Emission)  
EN55103-2:1996 (EMC Immunity)

**Done** Hermitage Tennessee USA, on 1<sup>st</sup> day of April, 2009.

\_\_\_\_\_  
signature on file  
Gary Gisting, President

This device complies with Part 15 of the FCC Rules. Operation is subject to the following two conditions:  
(1) this device may not cause harmful interference, and (2) this device must accept any interference received, including interference that may cause undesired operation.

Copyright © 2007, updated 2010 Creation Audio Labs, Inc. All rights reserved.

The Creation Audio Labs logo and MW1 Studio Tool logo are trademarks of Creation Audio Labs, Inc.  
All rights reserved.